

ELEVATION 'A'

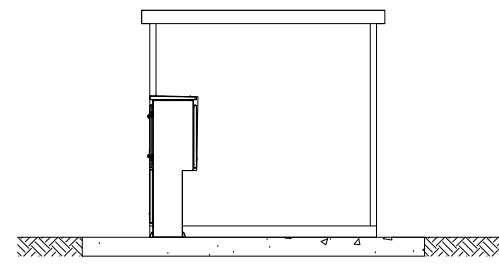

ELEVATION 'B'

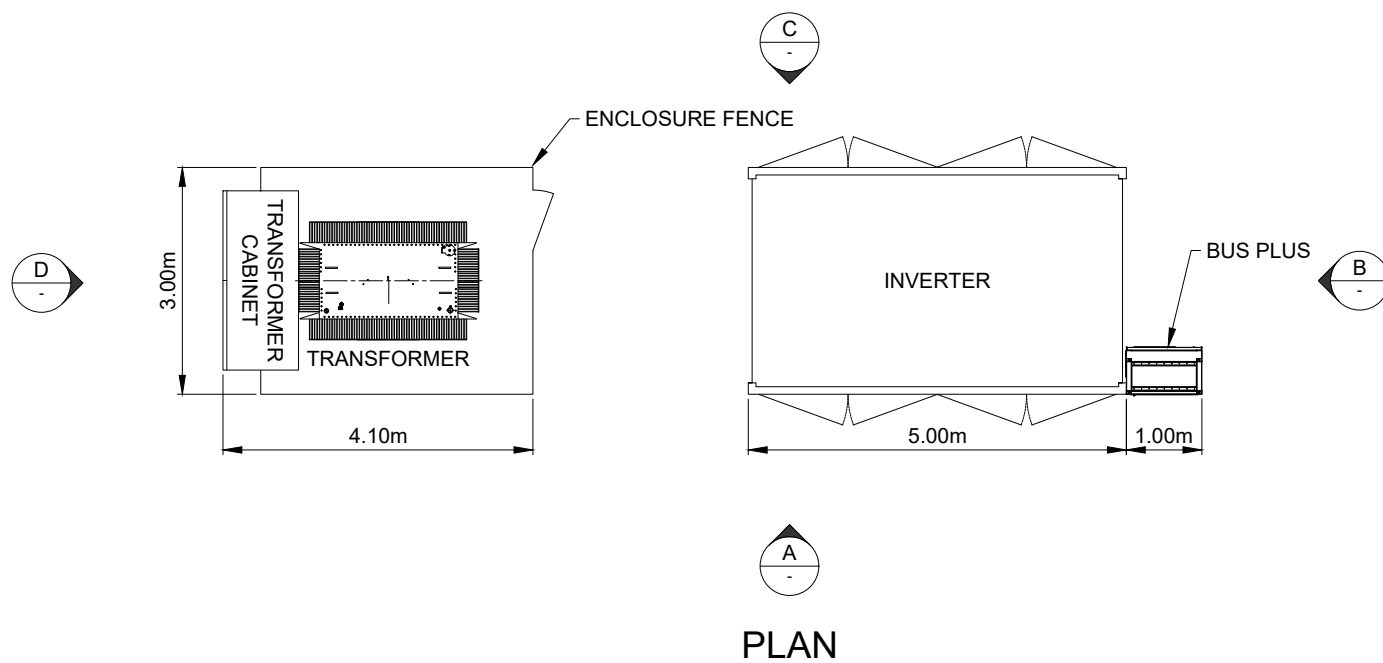

PLAN

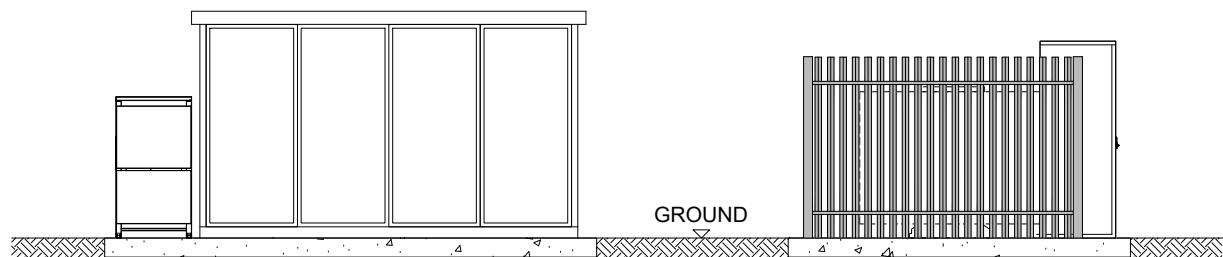

ELEVATION 'C'

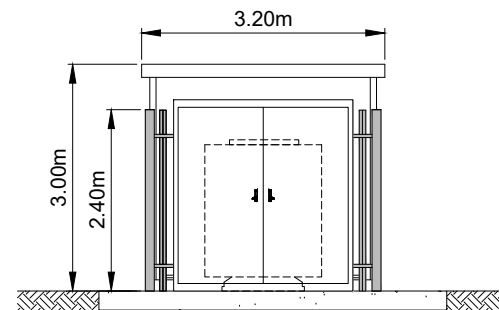

ELEVATION 'D'

NOTES

1. ALL DIMENSIONS ARE MAXIMUM ANTICIPATED AND SUBJECT TO DETAILED DESIGN
2. ROOM & DOOR POSITIONS ARE INDICATIVE AND SUBJECT TO DETAILED DESIGN.
3. APPROXIMATE FINISHED FLOOR LEVEL 0.30m ABOVE EXISTING GROUND.
4. LAYOUT ORIENTATION IS INDICATIVE AND SUBJECT TO DETAILED DESIGN.

1	FG	SM	JW	2024-07-05	First Issue
ISSUE	DRAWN	CHKD	APPD	DATE	REVISION NOTES
PURPOSE					COORDINATES
PERMITTING					N/A
SCALE					DATUM
1:100 @A3					N/A
LAYOUT DRAWING					T-LAYOUT NO
N/A					N/A

PROJECT TITLE  
**BEANE SOLAR**

DRAWING TITLE  
**FIGURE 8  
TYPICAL INVERTER SUBSTATION**

RES DRAWING NUMBER	REV
05003-RES-SOL-DR-PT-003	1

THIS DRAWING IS THE PROPERTY OF RENEWABLE ENERGY SYSTEMS LIMITED AND NO REPRODUCTION MAY BE MADE IN WHOLE OR IN PART WITHOUT PERMISSION



BEAUFORT COURT,  
EGG FARM LANE,  
KINGS LANGLEY,  
HERTS WD4 8LR, UK  
TEL +44 (0) 1923 299200  
WWW.RES-GROUP.COM